OWNER'S MANUAL SUPPLEMENT

SMART LIMIT for NER2 SERIES ELECTRIC CHAIN HOIST

1/8 and 5 Ton Capacities

Code, Lot and Serial Number

▲WARNING

This equipment should not be installed, operated or maintained by any person who has not read and understood all the contents of this manual. Failure to read and comply with the contents of this manual can result in serious bodily injury or death, and/or property damage.

HARRINGTON
HOISTS AND CRANES

9.0 Parts List

9.7 Smart Limit Parts

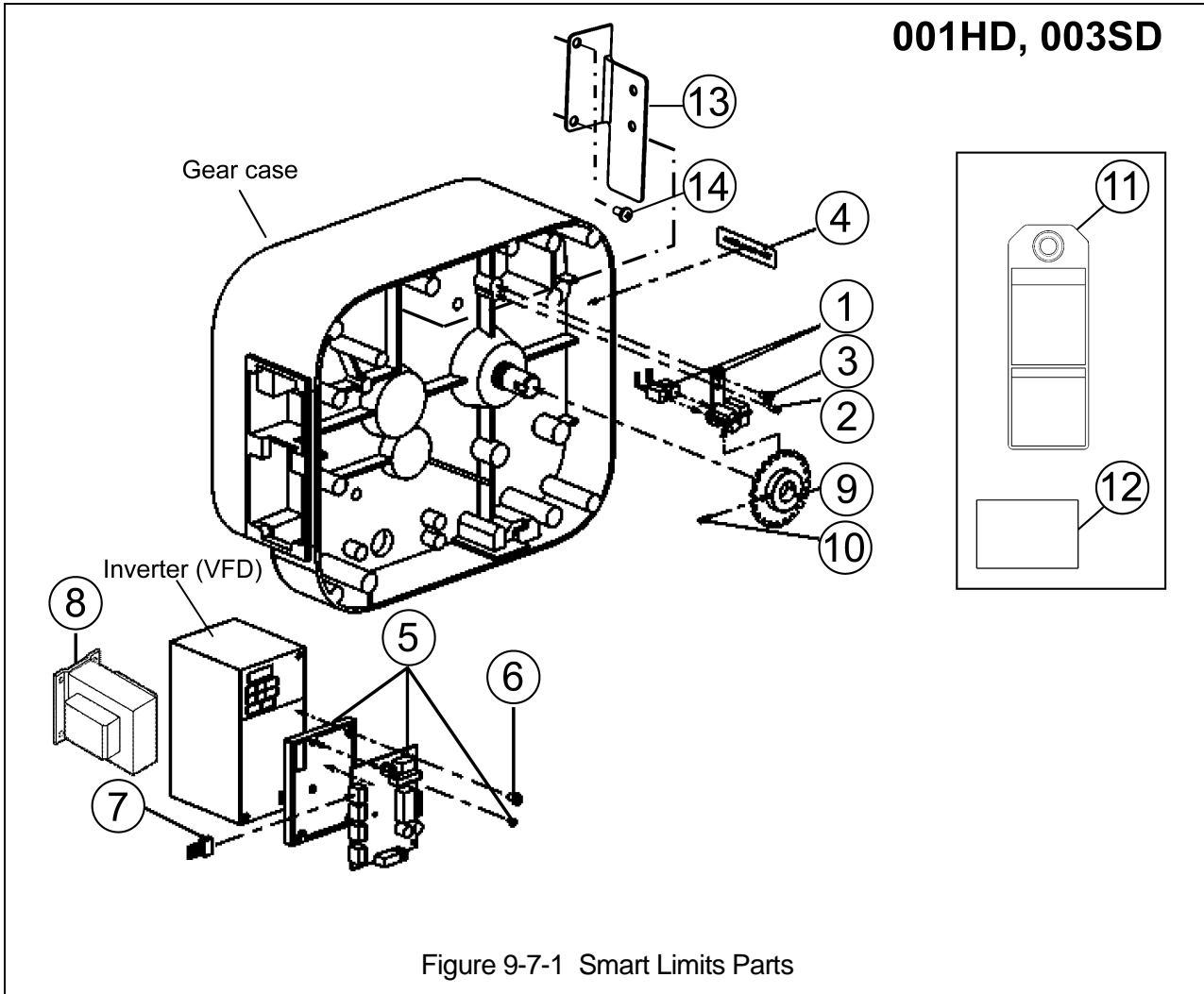

9.7 Smart Limit Parts

Figure No.	Part Name	Parts per Hoist	Part Number	
1	Photosensor Assembly	1	ER2BI1669	
2	Spring Pin	1	ES451005S	
3	Machine Screw with Spring Washer	1	J1AP25000808	
4	Smart Limit Label	1	80469	
5	Micro-computer Assembly	1	ER2BEE00I5B7	
6	Pan Head Machine Screw	1	J1AK23001515	
7	Micro-computer Lead Wire	2	ER2BHE03I9B3	
8	Transformer	1	2V	TRF32C912
			4V	TRF92N912
9	Trigger Wheel	2	ER2BS9674	
10	Socket Set Screw	1	J1TD1103008	
11	Smart Limit Warning Tag	1	80476	
12	Smart Limit Wiring Diagram	1	ER2BHE03I9B4	
13	Lead Wire Guard	1	ER2BI9667	
14	Machine Screw with Spring Washer	2	MS555010	

9.7 Smart Limit Parts

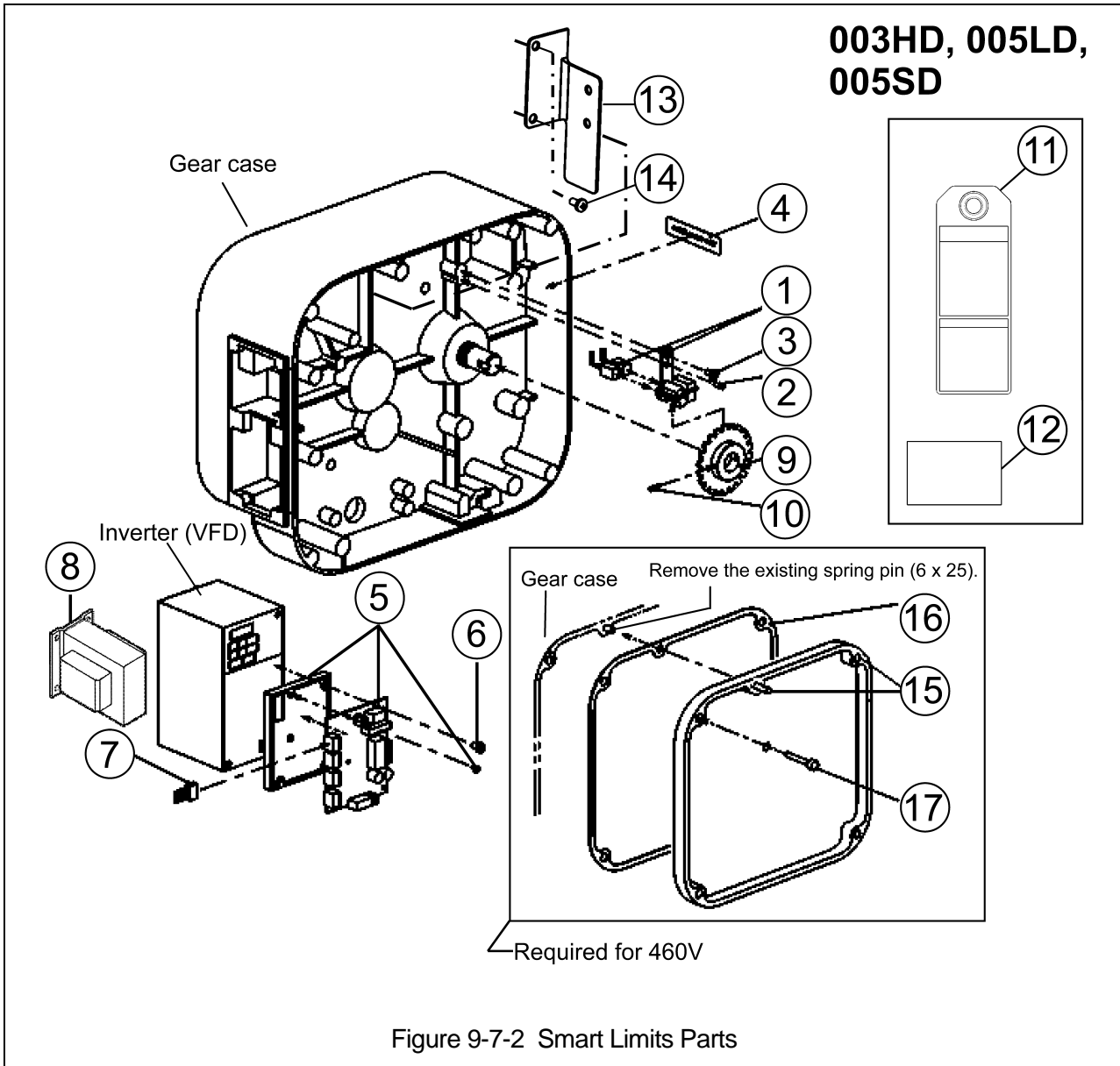

9.7 Smart Limit Parts

Figure No.	Part Name	Parts per Hoist		Part Number
1	Photosensor Assembly	1		ER2BI1669
2	Spring Pin	1		ES451005S
3	Machine Screw with Spring Washer	1		J1AP25000808
4	Smart Limit Label	1		80469
5	Micro-computer Assembly	1		ER2BEE00I5B7
6	Pan Head Machine Screw	1		J1AK23001515
7	Micro-computer Lead Wire	2		ER2BHE03I9B3
8	Transformer	1	2V	TRF32C912
			4V	TRF92N912
9	Trigger Wheel	2		ER2BS9674
10	Socket Set Screw	1		J1TD1103008
11	Smart Limit Warning Tag	1		80476
12	Smart Limit Wiring Diagram	1		ER2BHE03I9B4
13	Lead Wire Guard	1		ER2BI9667
14	Machine Screw with Spring Washer	2		MS555010
15	Spacer C Assembly	1	4V	ER2CS5684
16	Packing C	1	4V	ER2CS9117
17	Socket Bolt	4	4V	J1BE10505518

9.7 Smart Limit Parts

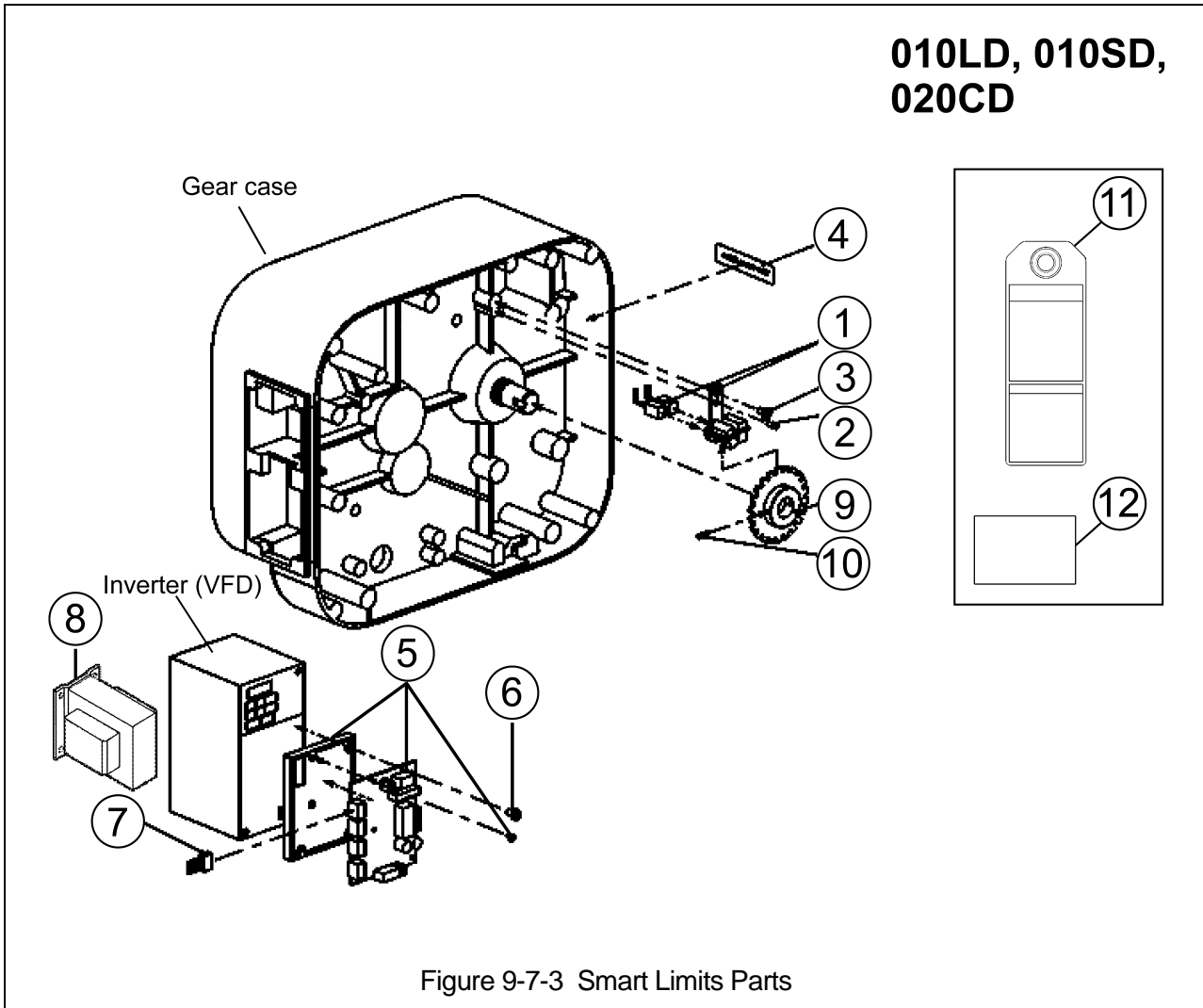

9.7 Smart Limit Parts

Figure No.	Part Name	Parts per Hoist	Part Number	
1	Photosensor Assembly	1	ER2BI1669	
2	Spring Pin	1	ES451005S	
3	Machine Screw with Spring Washer	1	J1AP25000808	
4	Smart Limit Label	1	80469	
5	Micro-computer Assembly	1	ER2BEE00I5B7	
6	Pan Head Machine Screw	1	J1AK23001515	
7	Micro-computer Lead Wire	2	ER2BHE03I9B3	
8	Transformer	1	2V	TRF32C912
			4V	TRF92N912
9	Trigger Wheel	2	ER2BS9674	
10	Socket Set Screw	1	J1TD1103008	
11	Smart Limit Warning Tag	1	80476	
12	Smart Limit Wiring Diagram	1	ER2BHE03I9B4	

9.7 Smart Limit Parts

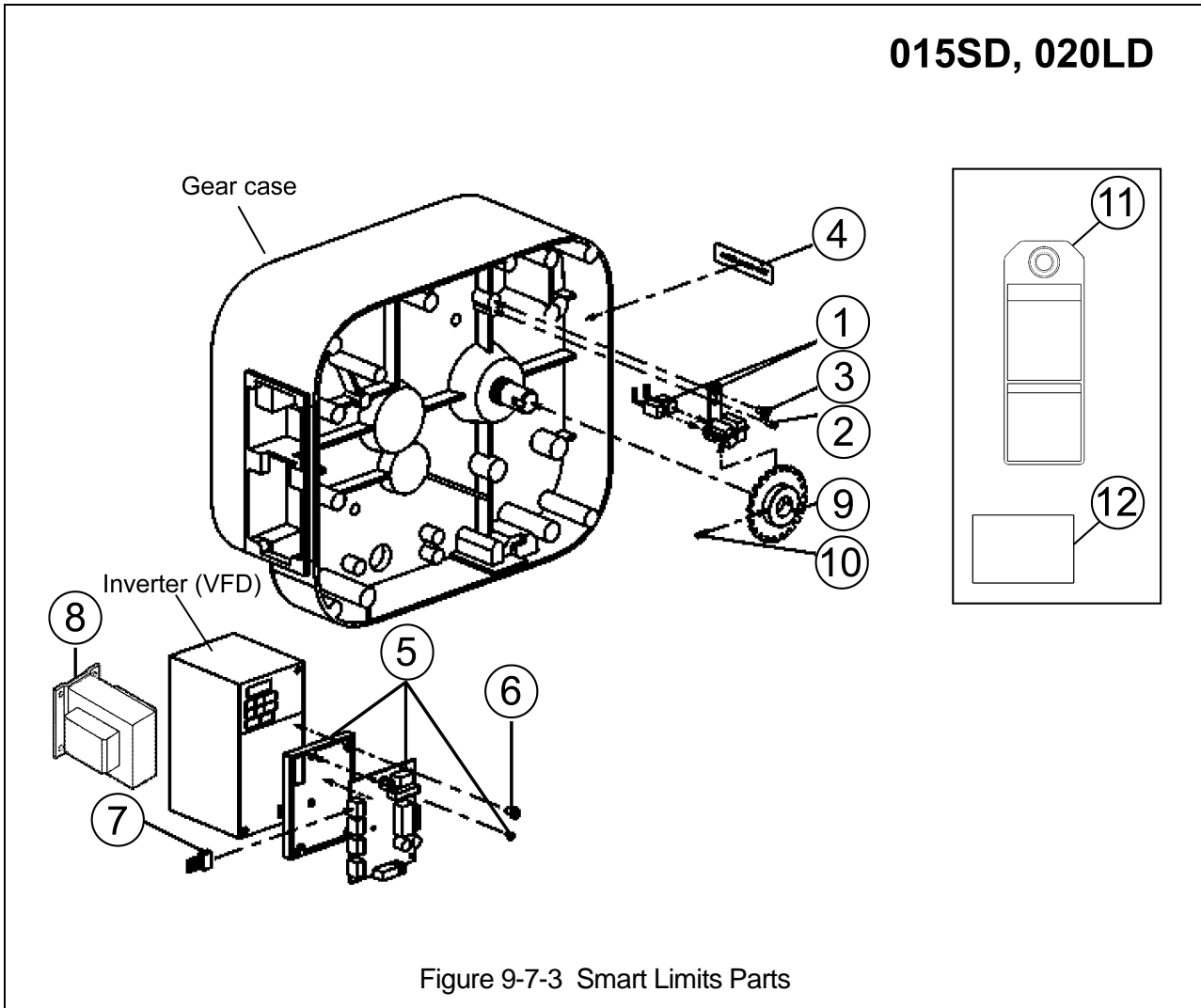

9.7 Smart Limit Parts

Figure No.	Part Name	Parts per Hoist	Part Number	
1	Photosensor Assembly	1	ER2BI1669	
2	Spring Pin	1	ES451005S	
3	Machine Screw with Spring Washer	1	J1AP25000808	
4	Smart Limit Label	1	80469	
5	Micro-computer Assembly	1	ER2BEE00I5B7	
6	Pan Head Machine Screw	1	J1AK23001515	
7	Micro-computer Lead Wire	2	ER2BHE03I9B3	
8	Transformer	1	2V	TRF32C912
			4V	TRF92N912
9	Trigger Wheel	2	ER2BS9674	
10	Socket Set Screw	1	J1TD1103008	
11	Smart Limit Warning Tag	1	80476	
12	Smart Limit Wiring Diagram	1	ER2BHE03I9B4	

9.7 Smart Limit Parts

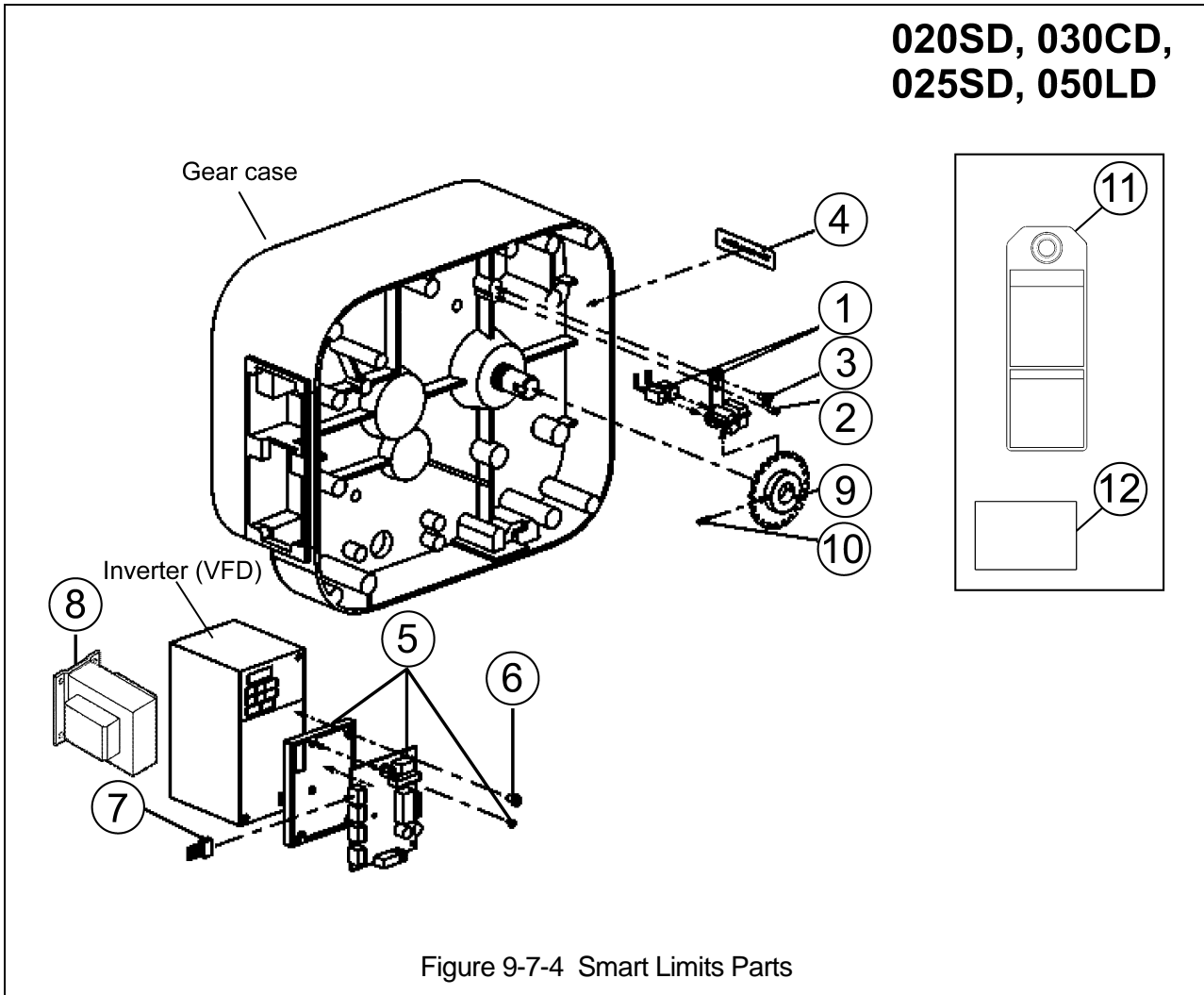

9.7 Smart Limit Parts

Figure No.	Part Name	Parts per Hoist	Part Number	
1	Photosensor Assembly	1	ER2BI1669	
2	Spring Pin	1	ES451005S	
3	Machine Screw with Spring Washer	1	J1AP25000808	
4	Smart Limit Label	1	80469	
5	Micro-computer Assembly	1	ER2BEE00I5B7	
6	Pan Head Machine Screw	1	J1AK23001515	
7	Micro-computer Lead Wire	2	ER2BHE03I9B3	
8	Transformer	1	2V	TRF32C912
			4V	TRF92N912
9	Trigger Wheel	2	ER2BS9674	
10	Socket Set Screw	1	J1TD1103008	
11	Smart Limit Warning Tag	1	80476	
12	Smart Limit Wiring Diagram	1	ER2BHE03I9B4	



www.harringtonhoists.com

Harrington Hoists, Inc.
401 West End Avenue
Manheim, PA 17545-1703
Phone: 717-665-2000
Toll Free: 800-233-3010
Fax: 717-665-2861

Harrington Hoists – Western Division
2341 Pomona Rincon Rd. #103
Corona, CA 92880-6973
Phone: 909-279-7100
Toll Free: 800-317-7111
Fax: 909-279-7500

NER2SLSUP